



safelift

Framed Trackless Door Gear

INSTALLATION INSTRUCTIONS



SAFETY FIRST Please read instructions right through before commencing installation.

CAUTION The spring is under tension – follow instructions carefully to avoid any chance of personal injury.

IMPORTANT INFORMATION

- 1 This garage door is intended for domestic use only.
- 2 Garage doors are heavy and may have sharp edges. Wear protective gloves. Installation should not be undertaken alone. Care must be taken when handling.
- 3 Ensure the door is continuously supported before it is secured and avoid installing in windy conditions.
- 4 Do not attempt to install or adjust this door if you are unsure of any of the instructions below.
- 5 Wear eye protection.

WARNING

When fitting the multi-point latching do not shut the door whilst you are outside the garage until all latches have been correctly set and tested (see instructions) Failure to comply could result in being locked out of the garage and a chargeable service call will be required.

IMPORTANT NOTES

BEFORE COMMENCING WORK:

- Remove all wrapping including plastic sleeve from spring. Ensure that your door has been supplied with the correct main fixing pack (fixing pack codes are on the identification label on reverse of door). Remove lock pack and fixing pack from their transit positions on the rear of the door.
- All the initial work is carried out from inside the garage so tools and parts should be to hand before door is placed in the opening.

FITTING TO BRICKWORK

Fitting within Aperture

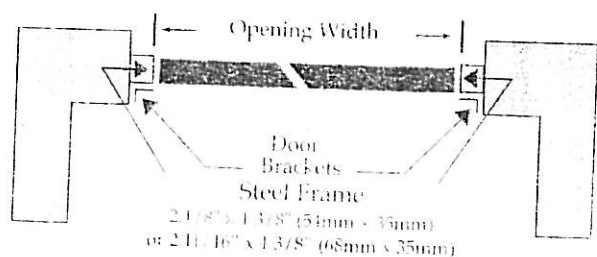

FIGURE i

Fitting Behind Aperture

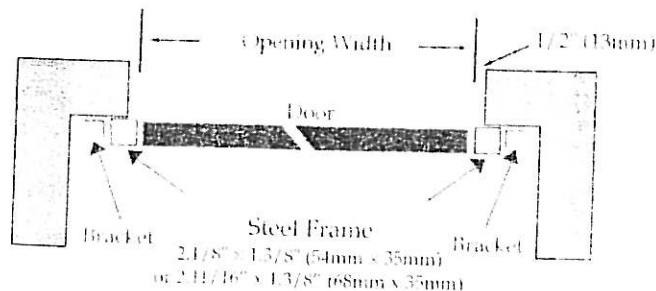

FIGURE ii

DIMENSIONS: Fitting to Brickwork

Option 1 – Steel frames 4 7/8" (108mm) more than door opening width, 2 7/8" (68mm) more than door opening height.

Option 2 – Steel frames 5 7/8" (136mm) more than door opening width, 2 7/8" (68mm) more than door opening height

Side jambs and top section of both frame options are 1 3/8" (35mm) deep.

INSIDE VIEW OF DOOR & GUIDE TO INSTRUCTIONS

NOTE A

No wall plugs are provided. It is the responsibility of the installer to provide and fit wall plugs suitable for the structure to which the door is to be fitted.

YOU WILL NEED

- 22mm A/F spanner
- 10mm A/F socket/spanner
- Posi screwdriver (Z3 & Z2)
- Protective gloves
- Eye protection
- Sharp knife
- Tape measure
- Hammer
- '3 in 1' type oil
- Grease
- Engineer's pliers
- Wedges (packing pieces)

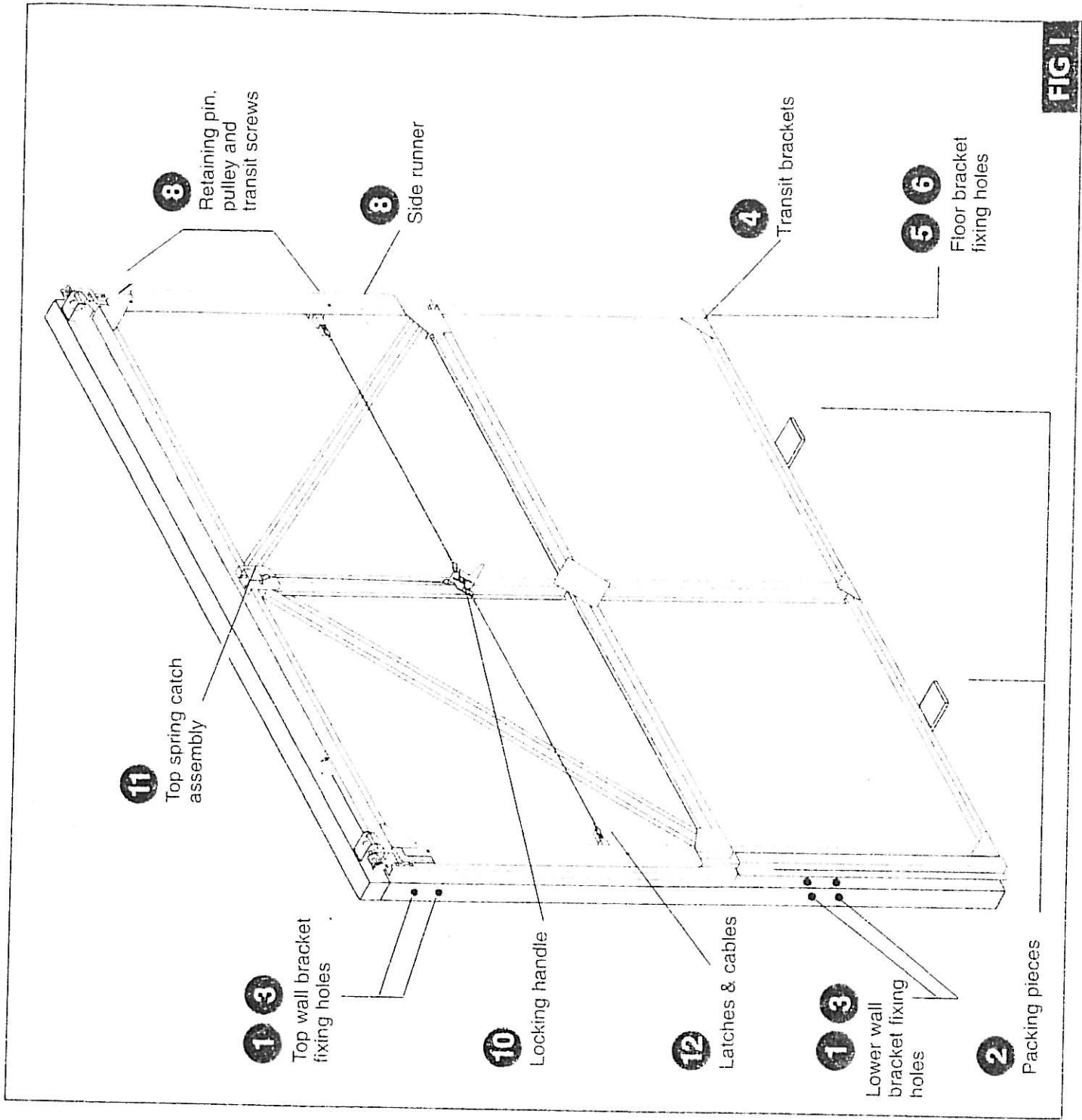

FIG 1

1 Select fixing positions and assemble wall brackets, fixing finger tight to frame using appropriate screws as specified below:-

A. For fitting frame within aperture brackets should be fitted to back face of frame as shown in Figure i on front page, as follows:-

i Fit lower bracket to both sides, slide slotted leg under the plastic side seal and fix with 2 off M6 Hex head Sem screws and plain washers per bracket.

ii Fit top bracket to both sides, slide slotted leg into gap at edge of frame and fix with 2 off M6 Posi screws with lock washers and plain washers per bracket.

NOTE – There is a maximum of 19mm (3/4") side adjustment on each bracket when fitting between brickwork.

B. For fitting frame behind aperture brackets should be fitted to side of frame as shown in Figure ii on front page.

Fit brackets to side edges of frame using 2 off M6 Hex head Sem screws and plain washers per bracket.

NOTE – For fitting frame behind aperture, it may be necessary to cut the wall brackets down to clear any side walls or pillars.

2 Place door unit central in aperture, wedging in position if necessary.

3 Fix brackets to wall. Secure using 2 off M7 × 45mm coach screws provided per bracket and with suitable wall plugs (see Note A).

4 Remove transit brackets from assembly. Retain M6 × 20mm hex head sem screws and discard No. 10 × 3/4" self tapping screws (Figure 2) and brackets.

5 Fit floor brackets finger tight to frame using M6 × 20mm hex head sem screws and plain washers previously saved.

6 Fix floor brackets to floor. Secure using 1 off M7 × 45mm coach screw provided per bracket and with suitable wall plugs (see Note A).

7 Check for final position and adjust if necessary. Ensure frame is square and vertical and that door is central, with an equal parallel gap either side.

Tighten up screws in all brackets.

8 A. IMPORTANT Ensure both cables are within side runners and correctly engaged in grooves of pulleys and into wheel spindle clips.

Take retaining pin out of Spring Anchor Bush with assistance of spanner on pulley (Figure 3). You now have tension on the door. Take out 2 transit screws from each upper weather strip. With door open insert 5 self tapping screws (No. 10 × 1/2") in slots down each side runner.

B. Open/close door through full travel to test runner position. If necessary make final adjustment to runners for correct operation.

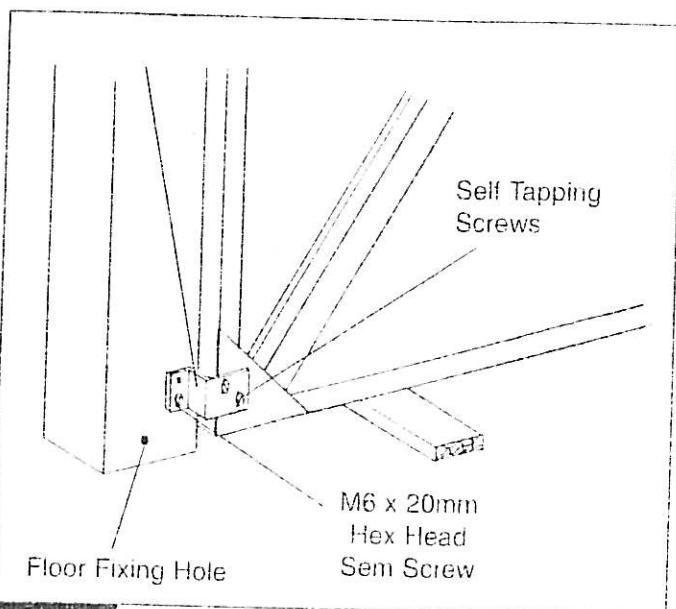

FIG 2

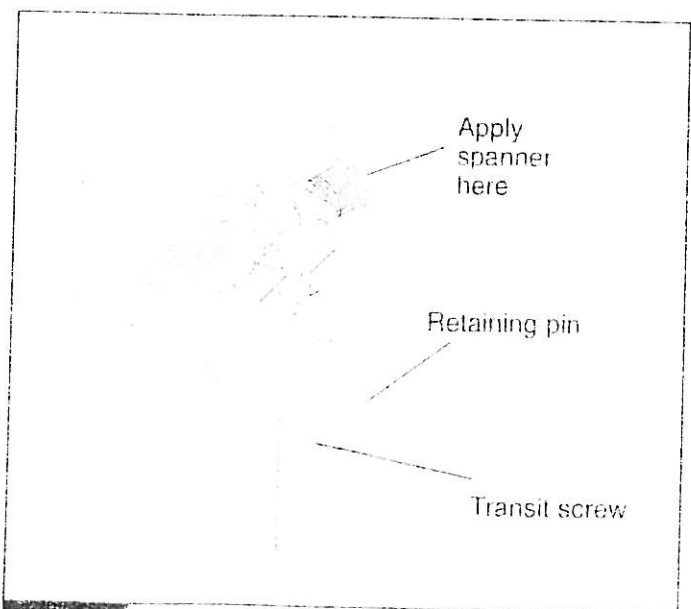

FIG 3

9 At this stage it is necessary to fit the lock. Refer to separate instructions provided with the lock pack for fitting procedure.

10 From the front of the door, ensure handle is turned fully anti-clockwise. From inside garage place plastic lock cam onto the square lock spindle in orientation shown in Fig 4. Fit latch lever over lock cam as shown and fix with self tapping screw and large washer provided.

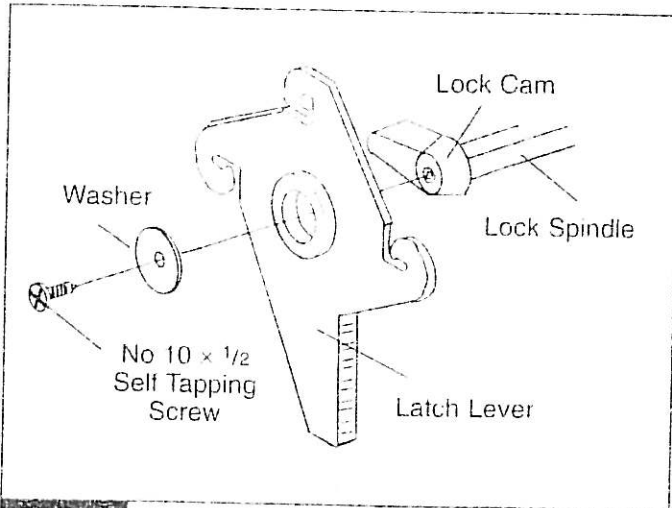

FIG 4

11 With the door slightly open take top spring catch assembly and engage into formed tag (see Fig. 5). Align fixing holes with those in top of door and insert self tapping screws (No. 10 x 1/2") provided. With door closed, remove park pin to release latch pin (see Fig 6). Align spring support/catch bracket centrally over latch pin with lower face level with the underside of the top lintel (see Fig. 6) Insert two M6 x 20 Hex Head Screws and washers, use sideways adjustments on screw slots to ensure correct alignment.

Take the shorter cable with single loop from pack and hook looped end onto top hook on latch lever.

Slide cable clamp over free end, route cable through hole in latch pin and return through clamp (see Fig. 5). **Note** Loop size not to exceed 25mm. Adjust length of cable to ensure correct catch pin engagement (see Fig. 6). Tighten screw in clamp on completion of adjustment.

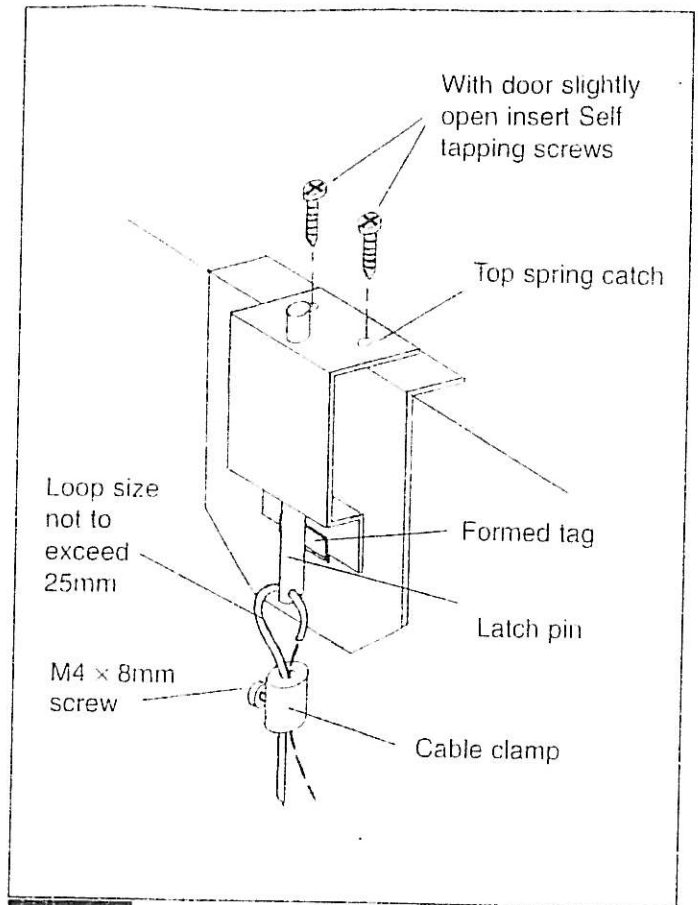

FIG 5

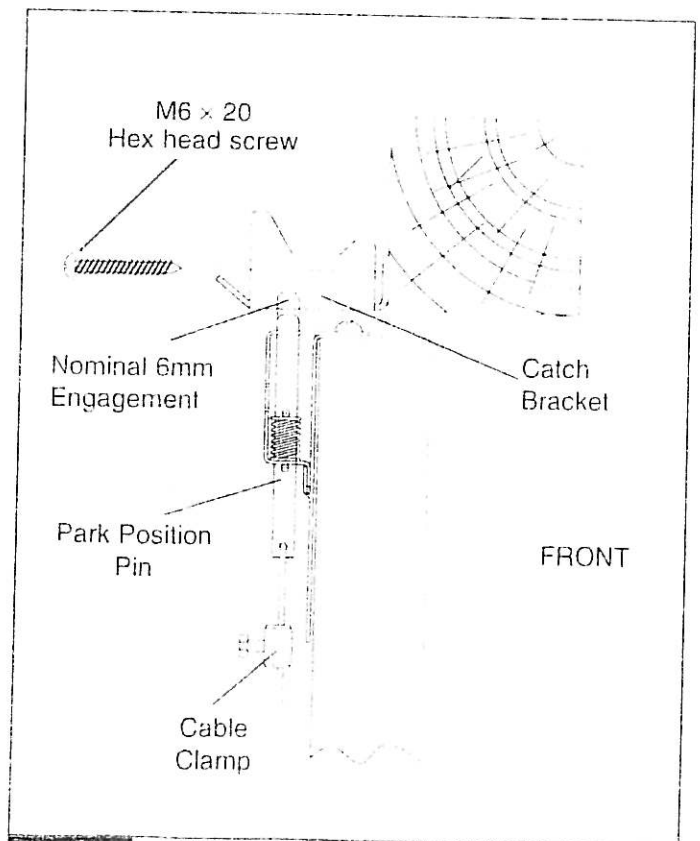

FIG 6

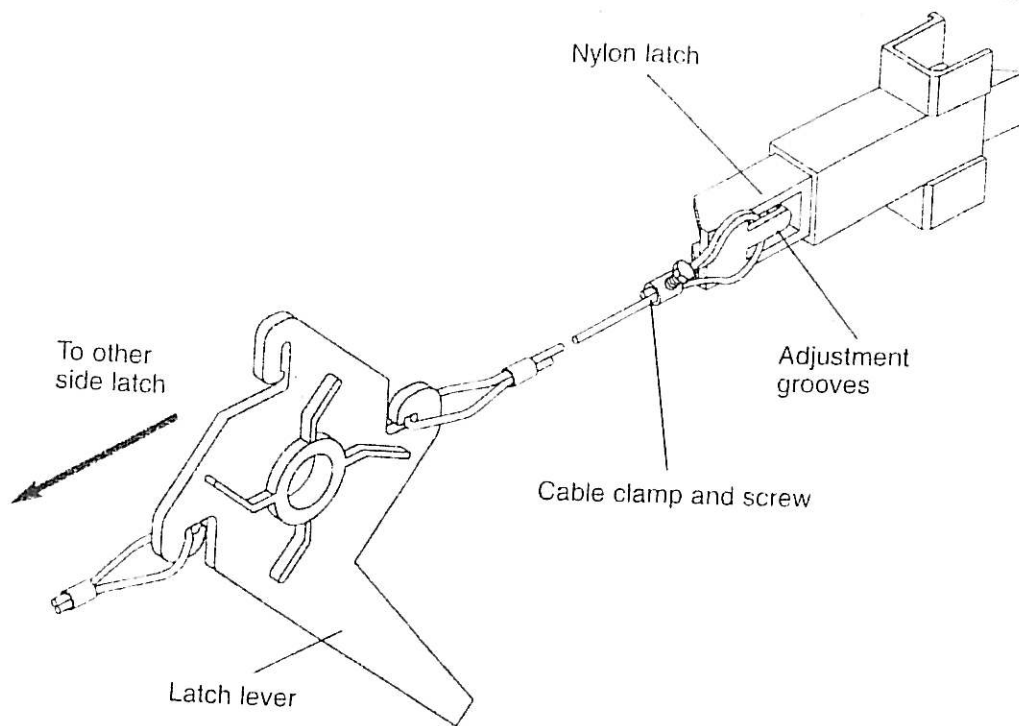

FIG 7

2 CAUTION Do not close door from outside until all latches have been checked for correct setting and operation. Failure to follow these instructions carefully may result in a lock out situation and a chargeable service call may result.

Take cable with double loop and attach looped end of cable (with clamp) in centre groove of nylon latch (see Fig. 7). Loop the other end of the cable over the closest arm on the internal latch lever. Repeat this operation for both side latches.

Adjustment may be necessary to ensure correct latch engagement. This can be done by either looping the cable over a different groove in the latch (see Fig. 7) or by loosening the screw on the cable clamp, moving cable slightly and re-tightening.

IMPORTANT Test latches for correct operation.

- Side latches should engage behind side runners by approx. 6mm.
- All latches should be fully released when the external lock handle is rotated clockwise.

NOTES ON COMPLETION

- On completion of installation lubricate the spring, wheel spindles and all pivot points with '3 in 1' type lubricant.
- Grease top catch pin to ensure smooth operation. (Do not grease side latches).
- Ensure track runners are clean.
- Check that all fasteners are fully tightened.
- It is the responsibility of the installer to ensure that the spring tension is correctly set. If the tension requires adjustment, refer to maintenance label on rear of door.
- Do not paint spring or any moving parts.



safelift

Framed Trackless Door Gear

DISMANTLING INSTRUCTIONS

THESE INSTRUCTIONS MUST BE FOLLOWED CAREFULLY

GARAGE DOORS ARE HEAVY AND AWKWARD TO HANDLE. ENSURE ASSISTANCE IS AVAILABLE AND THAT SAFETY GLOVES ARE WORN.

DOOR ONLY

1. Open door and remove the intermediate screws from the side runners, leaving the top and bottom fixings in place.
2. Wearing safety glasses, close door and grip R/H blue pulley with 22mm A/F spanner and by turning upwards, align holes in spring anchor bush and spring shaft. Insert retaining pin (4mm dia. x 50mm split pin or similar) fully into this hole as shown, then remove the spanner. (See Fig. 4)
3. Insert 4 off No. 10 x 1/2" self tapping transit screws through the top side seal to secure the side runners in place. (See Fig. 1)
4. Remove lower rubber weatherstrips. (See Fig. 1)
5. Remove 4 screws securing the two spring mounting brackets. (See Fig. 2)
6. Using cable ties, or strong cord, or similar, tie the spring assembly securely to the door panel.
7. Remove top catch bracket. (See Fig. 7)
8. Prop door in position.
9. Remove top and bottom track fixings including security block.
10. The door can now be carefully removed from the opening. Seek assistance in lifting.

DOOR AND FRAME

1. Remove any sealant from around the frame.
2. Insert No. 10 x 1/2" self tapping transit screws through the top side seal to secure the side runners in place. (See Fig. 1.)
3. Wearing safety glasses and with door closed, insert the retaining pin into the spring assembly. (See Fig. 3)
4. Remove wall mounting and floor fixing brackets which will allow the door and frame to be moved. Leave one screw per side securely fixed until assistance is at hand and you are ready to move the door and frame assembly.

IN THE EVENT OF DIFFICULTY PLEASE CONTACT YOUR LOCAL GARAGE DOOR SPECIALIST
– SEE YELLOW PAGES FOR DETAILS